

Fact Sheet

# STEINERT Splitcontrol

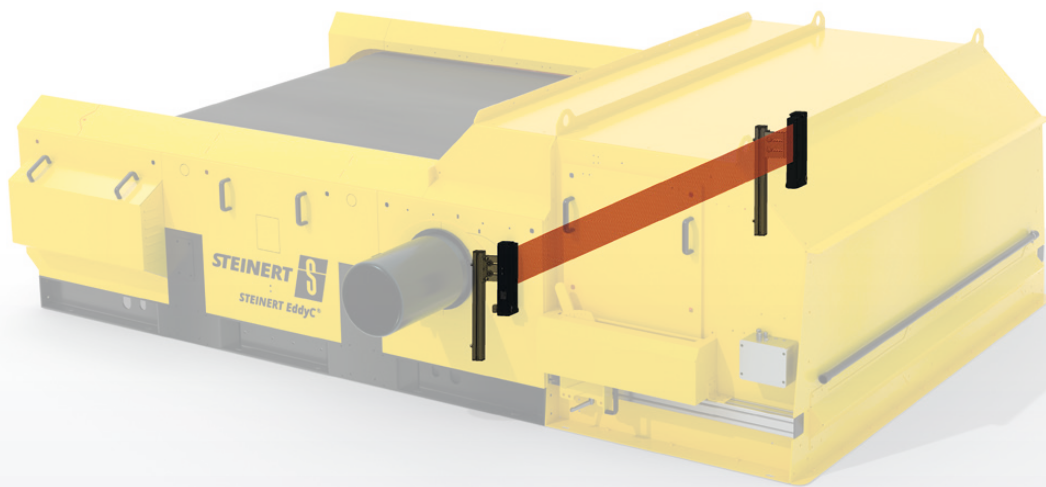

## + METAL SORTING

- + Automatically corrects the separating cut of a non-ferrous separator with changing material properties
- + Enables consistent separation results in fine grain
- + Optimizes the NF recovery of e.g. incinerated bottom ash

THE RESOURCE  
SEARCH ENGINE

**CURIOS?**  
Learn more.



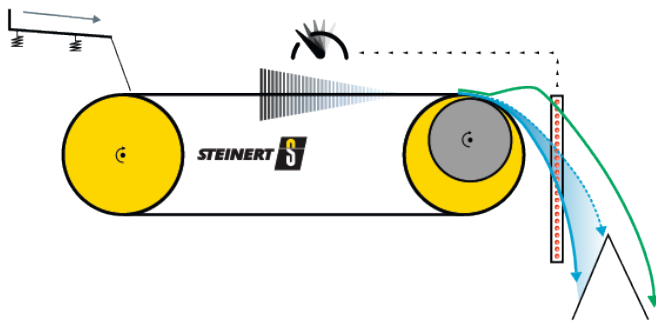
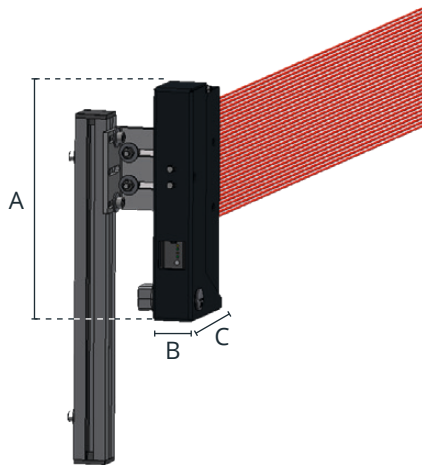

## + TECHNOLOGY

### STEINERT Splitcontrol

- + The spread of the sorting material is monitored in the drop area of the eddy current separator by means of a light grid.
- + The different discharge trajectories of the conductive (thrown/ejected) non-ferrous metals and the non-conductive residue (drop), which is unaffected by the magnetic field, can be assigned by software.
- + Automatic control of the belt speed ensures that the discharge trajectory of the drop is always close to the splitter plate so that the sorter can always be operated at the separation optimum.

### STEINERT Splitcontrol

#### General

Working width (mm)	Can be used for Eddy & EddyC	
Outer dimensions (mm)	A	286
	B	50
	C	110
Weight (kg)	20 (weight incl. light barrier, bracket, terminal box etc.)	

#### Environmental specifications

Permitted ambient temp. depending on version (°C)	-30 to +55
---	------------

#### Conformities

Given Conformities	CE, UL/CSA
--------------------	------------

#### Electrical specifications

Machine protection class	IP65
--------------------------	------

Technical alterations reserved. For more details see the operating instruction of the sorting system.